

Smart Cards

A SiPix ePaper Application

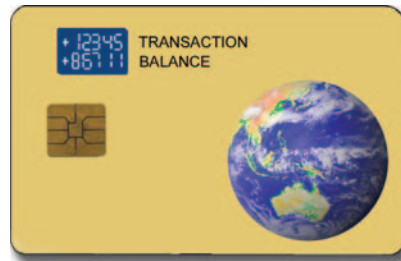

SiPix takes Smart Cards to a new level with ePaper displays. Unlike LCDs which are made with glass, our ePaper is extremely thin and flexible. Readable like paper, it is visible in sunlight with nearly a 180 degree viewing angle. Ideal for your power budget, SiPix ePaper prolongs battery life, drawing power only when switching due to its bistable image characteristics. Custom shapes enlarge your possibilities. With SiPix ePaper, Smart Cards may be designed with multiple color sections on the same display.

Design solutions. Established manufacturing. SiPix ePaper.

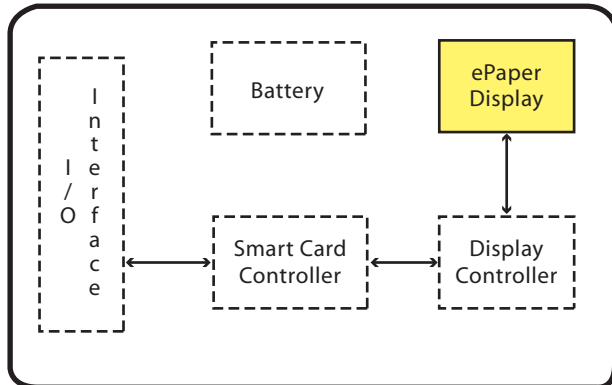

Key Applications

- Computer Security Systems
- Credit Cards
- Password Cards
- Electronic Cash/Campus Cards
- Loyalty Systems
- Banking
- Satellite TV
- Government Identification

Key Advantages

Paper-Like Readability

- Sunlight and non-uniform light visibility
- High reflectivity, superb contrast & resolution
- Viewing angle ~180°

Ultra-Low Power Consumption

- Long-Term Bistable Image - content preserved without power
- Prolonged battery life

Wide Design Latitude

- Repeatedly flexible, bending radius < 1 cm
- Thinner than 125 μm without backplane

Environmentally Robust

- Moisture and scratch resistant
- Pressure insensitive
- Impact resistant & user tolerant - no glass

Benefits

- Low power
- Moisture resistant
- Ultra-thin
- Bistable
- Bendable
- Multiple colors
- Pressure resilient

Color Options

SiPix ePaper displays may be designed with either a solid saturated color or with regions of different color on the same display:

- **Solid Color:** black, red, green, blue and gold
- **Sectional Color:** black, red, green, or gold combinations
- **Contrasting Color:** white
- **Grayscale Capabilities:** 16-levels
- **No Color Filters Used**

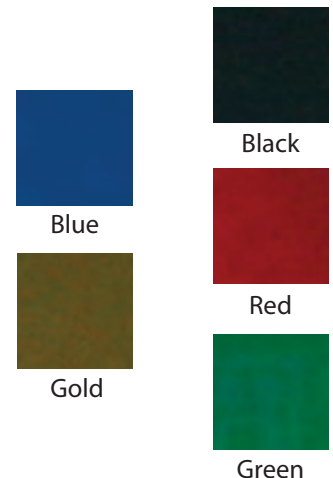

SiPix ePaper Applications

Electronic Shelf Labels
Smart Cards
Instrument Displays
Medical Devices

Point of Purchase (POP) Signs
Public Information Signs
e-Books / e-Newspapers
e-Billboards

PDAs
Watches/Clocks
Calculators
Giftware

Board Games
Toys
Handheld Games
Fashion Apparel

Why SiPix?

With SiPix ePaper, designers may now choose from multiple saturated color combinations, custom sizes, and material that will not break down with abuse or moisture.

We offer display module services to get you to the market quickly. Our established manufacturing line will give you economy and scale.

Choose SiPix as your ePaper partner and enjoy unrivaled insight into the world of paper-thin, readable displays.

Electrophoretic Displays

Introduced in 1969, Electrophoretic Displays (EPDs) are highly reflective. Under the influence of an applied electric field, charged white particles migrate through a colored dielectric to produce a display that reflects the color at the surface from either the particles or the dielectric. SiPix EPDs are known for their wide viewing angle, image bistability, and low power consumption.

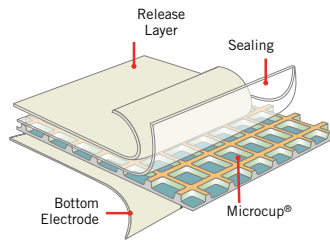
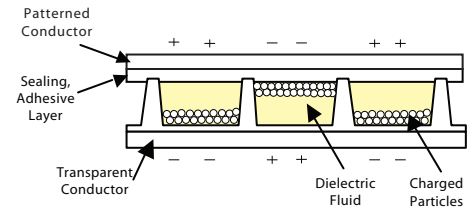

The SiPix Microcup® structure allows for the thinnest and most flexible electronic display. The partition walls provide not only fine resolution but also excellent mechanical support for impact resistance. Each Microcup® is individually sealed, enabling the EPD film to be custom cut to desired shapes and sizes.

Roll-to-Roll Manufacturing

SiPix produces ePaper using a roll-to-roll process. On a continuous plastic substrate, our EPD material is created with coating, embossing, sealing and lamination processes. With the industry's first roll-to-roll production process for electronic paper films, we have the experience and scale to meet your high volume needs of display material that is reliable, extremely thin, and flexible.

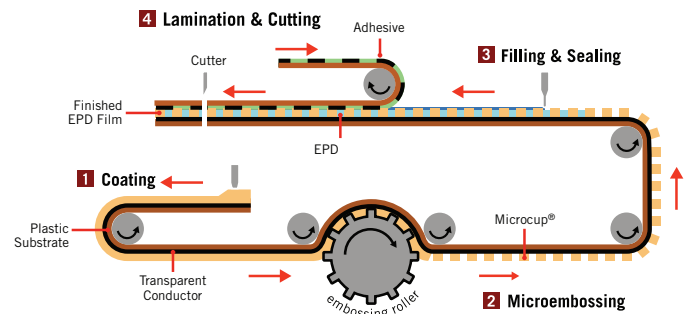

SiPix Corporate Profile

SiPix Imaging, Inc. is a world leader in display innovation. With a roll-to-roll production facility in Fremont, California, the company manufactures flexible Electrophoretic Display material, cuttable to custom size. In Taiwan, a SiPix backend production facility provides multiple-application display modules for rapid system development. Manufacturing technology transfer is also available for increasing efficiencies in existing client production.

For more information, contact SiPix directly or go to the web at www.sipix.com.



SiPix Imaging, Inc.
47485 Seabridge Drive
Fremont, CA, 94538, U.S.A.
Tel: 510-743-2916
Fax: 510-743-2872
sales@sipix.com
www.sipix.com

© 2005 SiPix Imaging, Inc. All rights reserved. SiPix and the SiPix logo are trademarks of SiPix Imaging. The information presented in this document is believed to be accurate and reliable but may contain errors or omissions and is subject to change without notice. This material is provided as is and without any express or implied warranties, including merchantability, fitness for a particular purpose and non-infringement. SiPix Imaging shall not be liable for any special, indirect, incidental or consequential damages as a result of its use.